



# STANDARD INSTALLATION MANUAL

## **puraDYN Bypass Oil Filtration Systems**



**M03**

(prev. MTS8)



**M06W**

(prev. MTS12)



**M06**

(prev. MTS8x12)



**M10**

(prev. MTS24)

# Table of Contents

<b>TABLE OF CONTENTS</b> .....	<b>2</b>
<b>Overview</b> .....	<b>3</b>
How the <b>puraDYN®</b> Bypass Oil Filtration System Works .....	3
<b>SEQUENCE ( I ) - Installation Steps Overview</b> .....	<b>4</b>
Vertical Clearance Requirements .....	5
Mounting Instructions .....	6
<b>SEQUENCE ( II ) - Install Oil Supply (Pressure) Line</b> .....	<b>7</b>
Proper installation of Reusable Fittings to Hose(s) .....	8
<b>SEQUENCE ( III ) - Install Oil Return Line</b> .....	<b>9</b>
Determining Oil Return Location & Hose Routing .....	10
<b>SEQUENCE ( IV ) - puraDYN® System Start-Up</b> .....	<b>11</b>
<b>Sampling Oil Procedures</b> .....	<b>12</b>
Oil Analysis Data Interpretation .....	13
Oil Analysis and Service Schedules .....	14
Troubleshooting.....	15
<b>Questions &amp; Answers</b> .....	<b>16</b>
<b>Maintenance:</b> .....	<b>18</b>
Filter Element Service Requirements .....	19
Required Tools and Items for <b>puraDYN®</b> System Installation .....	20
<b>PRODUCT LIMITED WARRANTY</b> .....	<b>21</b>
<b>PRODUCT LIMITED LIABILITY GUARANTEE</b> .....	<b>22</b>
<b>OIL ANALYSIS AND SERVICE SCHEDULE RECORDING TEMPLATE</b> .....	<b>23</b>
<b>REGISTER YOUR PRODUCT FOR WARRANTY COVERAGE</b> .....	<b>24</b>

## **Overview**

This installation manual is designed to assist you in the installation of your new **paraDYN®** Bypass Oil Filtration System.

This manual will go over all aspects of installing the **paraDYN®** System on most oil-lubricated equipment. The information in this manual will also assist you in custom installation of a new **paraDYN®** System on generators, marine, heavy construction, and other applications. At any time during the installation, if you have questions, please call our technical support team.

### **How the *paraDYN®* Bypass Oil Filtration System Works**

The **paraDYN®** System has no moving parts and is designed for years of trouble-free operation. Working in conjunction with the OEM full flow filter, our systems continuously clean oil and improve engine performance with reduced component wear.

Engine oil enters the **paraDYN®** filter through a metering jet located inside the base of system's housing unit. The metering jet reduces the flow of oil going through the **paraDYN®** filter to approximately 6-8 gallons per hour.

Oil passes through our patented Polydry® polymer which absorbs harmful liquid contaminant (water) that is emulsified in the oil. The oil continues to flow through cotton media treated with CGP®, a process for chemical grafting, which naturally traps other solid contaminants down to below one micron in size.

Certain **paraDYN®** filter elements also include a time-released additive package designed to replenish depleted base additives specific to engine type, thereby maintaining the oil's chemical balance and viscosity. The clean oil then exits the system through a return line back to the oil pan or sump. This cycle continues as long as the engine or equipment is operating.

When you would typically change oil, as recommended by the OEM, complete an oil analysis and replace the **paraDYN®** filter element. If the oil analysis confirms the oil is still safe to use, there is no need to change it.

**Note: Use of anything other than a genuine paraDYN® Filter Element voids the paraDYN® Product Warranty.**

## **SEQUENCE ( I ) - Installation Steps Overview**

**Note: See Required Tools section (page 20)**

1. Verify parts received.
2. Call Puradyn toll-free 1-866-787-2396 (in North America) or +1 561 547 9499, if any parts are missing or damaged.
3. Read this installation manual to become familiar with the installation process.
4. Survey equipment or vehicle to determine the mounting location.
5. Verify adequate physical housing unit clearance, accessibility of oil sample valve & room for oil sample bottle; also, check that there is enough clearance to change filter element.
6. Inspect the new pre-assembled (Plug and Play) housing unit and other accessories.
7. Use a mounting-hole template to locate the mounting holes onto the designated location.
8. Drill out the holes; install the center hinge-pin bolt with about ½" slack.
9. Hang the pre-assembled system onto this center hinge-pin bolt. Tighten up slightly and position other mounting holes to be lined-up with the L-bracket plate. Fastened all the mounting bolts onto the firewall or structural frame-wall.
10. Attach oil supply line to **puradYN**<sup>®</sup> System and engine or equipment's supply port (ex. oil galley).
11. Attach oil return line to **puradYN**<sup>®</sup> System.
12. Drain old oil completely from equipment, taking an oil sample of the drained oil to use as a reference of the current engine and oil condition.
13. Install new OEM full flow filter per OEM instructions.
14. Connect other side of oil return line to engine or equipment's (non-pressurized) sump.
15. Refill engine with new oil, taking another oil sample to establish a base line of the new oil that will be used.
16. After system installation is completed, please go to System Start-Up section of this manual for a step-by-step start-up/operation test.

### **Important Continuous Maintenance Reminders**

- Please review maintenance schedule for recommended filter change intervals –if you need help generating your oil service interval schedule with **puradYN**<sup>®</sup> System, please call Puradyn's technical support TEAM.
- Use oil analysis to confirm oil is good for continued use.
- Maintain a good preventive maintenance program on engine and equipment.
- Routinely check oil level using engine dipstick.
- Change oil according to oil analysis recommendation.
- Please reference System Startup page for adding required quantity of (make-up) oil and note, the added oil must be compatible with oil already in the system. Example. API-CJ-4 (API category and brand may have differences in the additive package).

## Vertical Clearance Requirements

In order to change the filter element after installation, the following minimum height requirements (clearance dimension) **above** each housing unit must be maintained:

### Vertical Clearance Dimension:

*M03 8 INCHES*  
*M06W 8 INCHES*  
*M06 12 INCHES*  
*M10 12 INCHES*

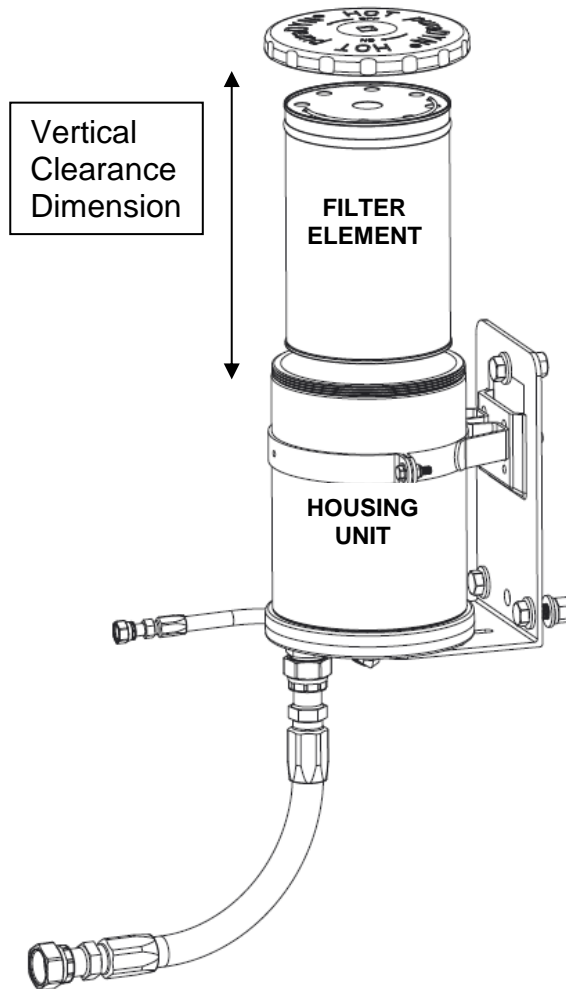

**Location:** Choose a secure mounting location on the fender well, firewall, frame rail, vertical post, beam or cowl that meets these requirements.

- Install system near oil return port (sump) and keep the return hose as short as possible. Do not mount system directly onto the engine.
- Maintain enough space in both the horizontal and vertical direction so the system (including mounting hardware) will not interfere with engine parts, suspension components, steering linkage, brake lines, electrical system or engine control hardware. Check for moving component clearance: i.e. tire clearance, right full turn, left full turn while suspension is unloaded and fully loaded.
- Select thick gage mounting frame location, so the weight of the system doesn't cause metal fatigue or damage.
- Keep a safe distance from hot exhaust system components.

**CAUTION! Avoid high-vibration mounting locations, which can cause the bolts to loosen during operation.**

## Mounting Instructions

Mount the **puradYN**® housing unit vertically and level.

**Note:** Puradyn Filter Technologies Incorporated stocks various sized pre-drilled mounting plates for installation. If you would like installation technical assistance, please call Technical Support toll-free (in North America) at 1-866-787-2396 or +1 561-547-9499.

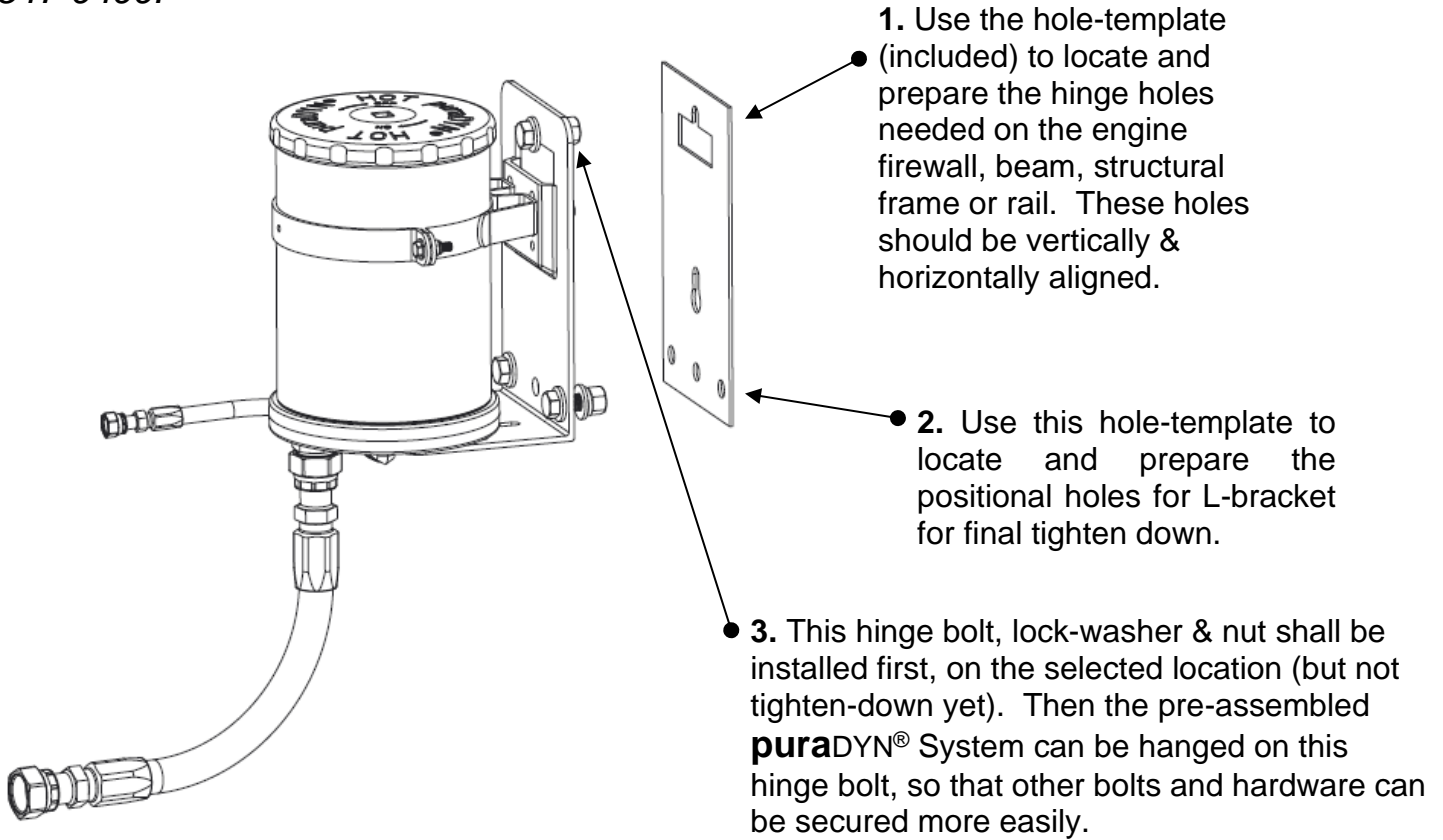

**CAUTION:** Always check/consult with the Original Equipment Manufacturer for approval first before drilling any new holes (or welding) into equipment frame rails, firewall, beam, post, etc.

**Puradyn recommends** utilizing existing holes, where possible, in the frame rail, firewall, beam or structural frame to mount the L-bracket.

**Note:** Mounting clamps/brackets, pads and hardware may vary from above illustration.

## SEQUENCE ( II ) - Install Oil Supply (Pressure) Line

### Typical Oil Supply Line Connection

1. Locate oil galley plug, oil pressure sending unit or other pressurized oil port or galley.

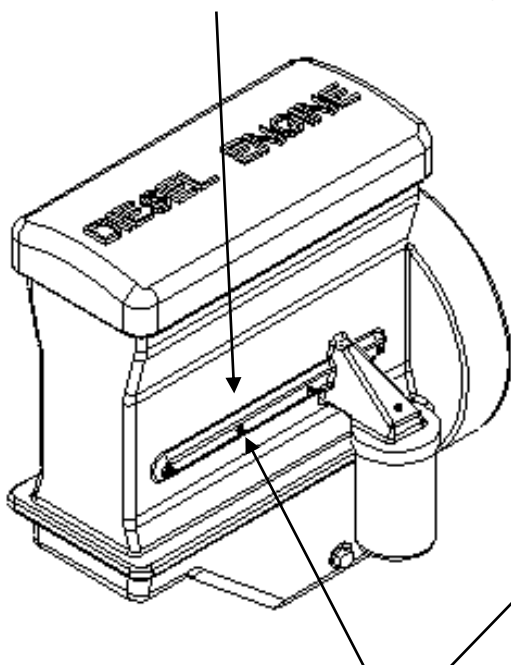

2. Install shutoff valve fitting to oil supply port. Connect high-pressure hose (prepared earlier) to this installed shutoff valve fitting.

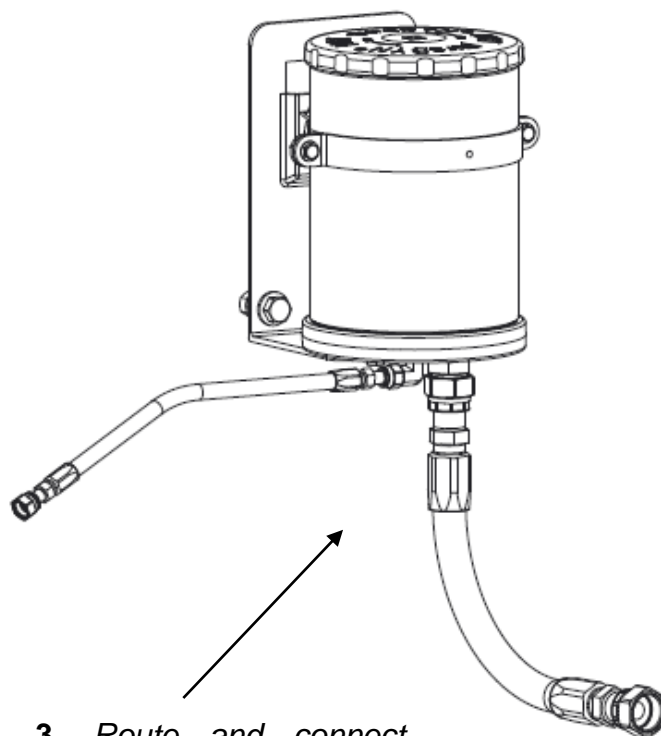

3. Route and connect high-pressure hose from **Step 2** to supply fitting (or optional sample valve kit) on the bottom of the housing unit.

Sample Valve kit  
Option: 15-00245

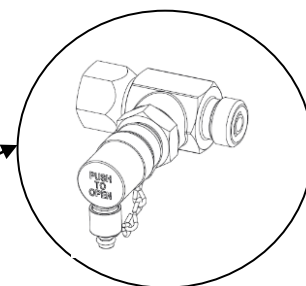

### Install pressure port fittings

**Step 1.** Find the oil pressure sending unit or port plug along oil galley on the engine. The oil pressure sending unit normally has a wire or cable running to the ECU. If you are unable to connect to the oil pressure sending unit, find another pressurized oil port (usually near the factory full-flow oil filter) that you can connect to for oil supply. **Note: It is recommended to put a gage on the selected port and run the engine at high idle to verify the oil pressure under operation. As long as the oil pressure is under 65 psi, you can install the standard metering jet. If the pressure is above 65 psi, please contact Puradyn technical staff for recommendation.**

**Step 2.** After locating the oil port that you will be connecting to, install the shutoff valve supplied from the kits bag, and install the fitting to the oil port (also, a 1/8" street tee and 1/4" NPT bushing have been supplied for different adaptation).

**Step 3.** Route the high pressure hose from **Step 2** to the bottom of the housing unit and connect it to the supply fitting. **Note: After system installation is complete, remember to open the Shutoff valve, so the oil can travel from the engine to the puraDYN® System.**

### Proper installation of Reusable Fittings to Hose(s)

The puraDYN® System operates with the use of a pressurized oil supply from the engine oil pump. The return and supply hoses are not included in the standard model, but can be supplied by Puradyn Filter Technologies Incorporated, your dealer, hydraulic parts store, and most auto parts stores – these are sometimes custom made for specific kits where length of hose has been pre-determined.

### Specifications

- Use 3/16" I.D., 3000 psi fully braided hose rated for hydraulic oil (Puradyn part# 08-00003 or Weatherhead # H06904 or Aeroquip # FC350-4 or equivalent).
- Use proper sealants for installation of all fittings.

Take the two supplied high-pressure flared reusable fittings and install them in the following manner:

- a. The shoulder nut has a reverse thread and must be screwed on in a counterclockwise direction. As soon as the nut starts to thread, insert the flared insert portion into the shoulder nut about three turns.
- b. First, tighten down the shoulder nut, with a 5/8" wrench. Next tighten the flared insert, with a 9/16" wrench. Do these steps on both fittings.
- c. Remove both flared inserts, as during the threading process, the inserts pick up a small piece of rubber, which must be completely removed from hose. Re-install both flared inserts and blow out with high pressure air to clear out all the debris.

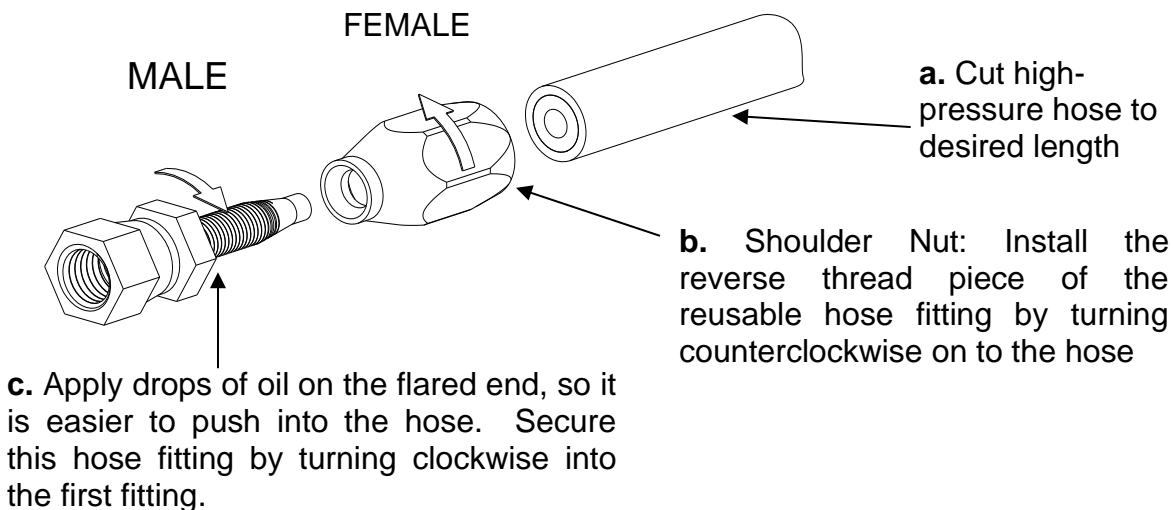



## SEQUENCE ( III ) - Install Oil Return Line

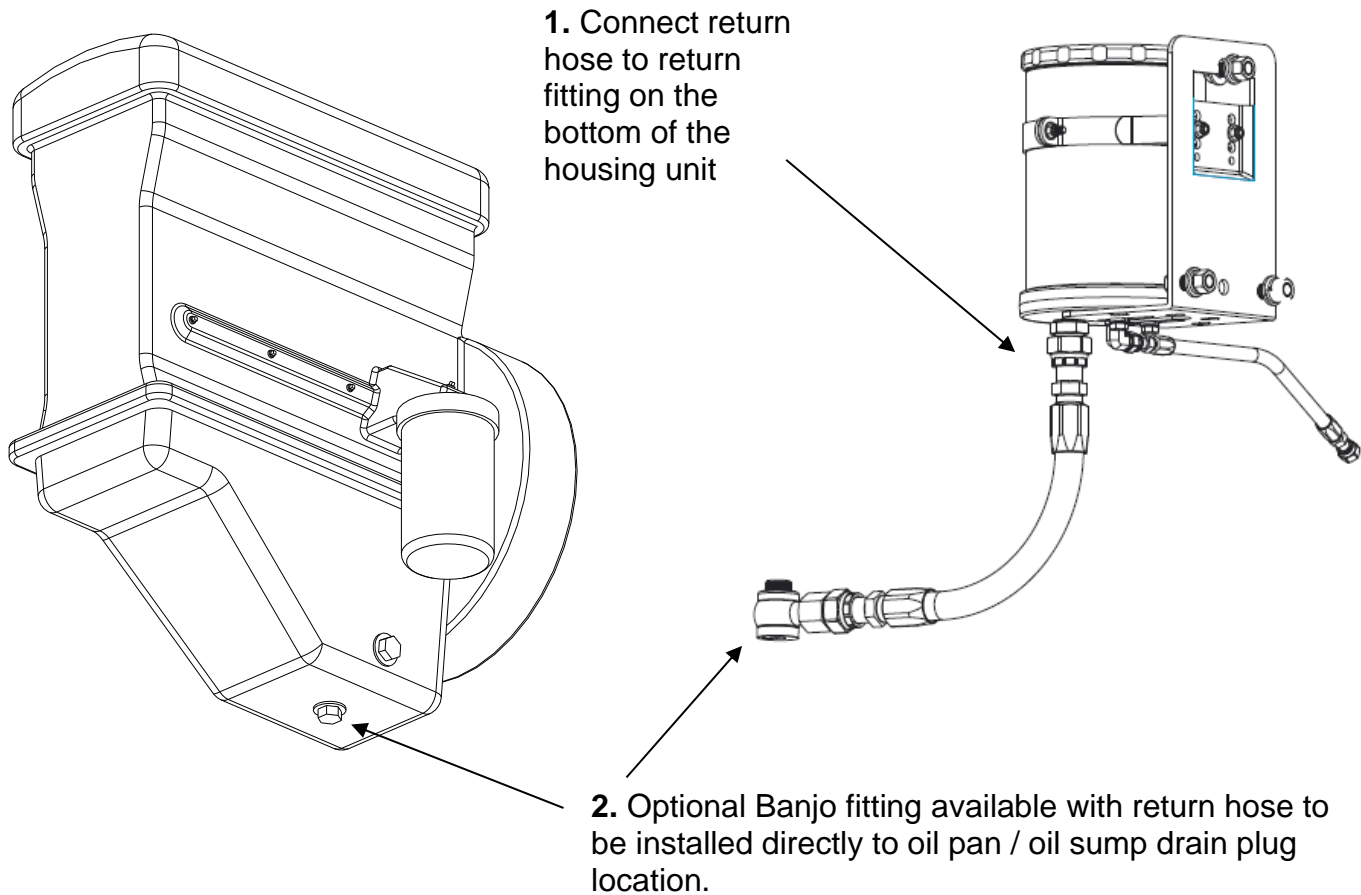

**Step 1.** Locate and install the return fitting into the oil drain plug port. You may use a 90° elbow fitting or optional banjo fitting to simplify hose attachment.

**Step 2.** Route the return hose to the bottom of the housing unit and connect to the O-Ring Face Seal (ORFS) return fitting.

**Note:** Banjo fittings are optional. They are NOT supplied with the **puradYN**® housing unit.

The return and supply hoses are not included in the standard model, but can be supplied by Puradyn Filter Technologies Incorporated, your dealer, or a local hydraulic parts store that offers DOT rated hose. These hoses are sometimes custom made for specific application where length of hose has been predetermined.

**Specification:** Use 13/32" I.D., 2000 psi, oil-rated hose, (Puradyn part# 08-00024, Parker 201-8 or equivalent).

**Note:** A full braided steel hose should be used with **puradYN**® System's optional Off Road Kit, whenever the return hose will be exposed to external debris or rubbing. Please call Puradyn for consultation if equipment required this option.

## **Determining Oil Return Location & Hose Routing**

Locate and determine best locations to attach the oil return fitting.

- The oil pan
- The oil drain port
- An inspection port on the side of the oil pan or sump.

### **Use the following criteria to select an oil return port on the engine:**

- The oil return port should be a condition of very low-pressure or non-pressurized port on the engine. There shall not be high backpressure on return flow.
- A low-pressure or non-pressurized oil port location should be selected for connection of oil return line fitting, engine location, such as the drain plug on oil sump, an alternate oil fill cover, or any other low-pressure or non-pressurized port location on engine.

### **Determine optional banjo fitting size:**

Once a Return location is selected, make sure that you have the correct banjo fitting to attach to the oil return port. If your Banjo fitting size is not listed on website, please call Technical Support toll-free (in North America) at 1-866-787-2396 or +1 561-547-9499 for assistance.

## **Return Fitting Connection and Hose Routing**

Remove oil pan drain plug and drain the old oil from the oil sump, take an oil sample so that it can be analyzed and compared with future oil analysis.

After replacing the drain plug with **puradYN**<sup>®</sup> banjo fitting, install one reusable ORFS hose fitting to the return hose, and connect to the installed banjo fitting. Route the return hose to the bottom of **puradYN**<sup>®</sup> housing unit. Pre-measure, pre-cut return hose to the proper length, installing the other side with the reusable ORFS hose fitting. Before connecting, make sure the hose is clean and there is no debris stuck in the line (use pressurized air to blow out the debris, etc.).

**When routing the oil return hose from the **puradYN**<sup>®</sup> system to the engine, make sure that the hose does not come in contact with abrasive or moving parts or hot exhaust components. Secure the hose using supplied tie wraps.**

## SEQUENCE ( IV ) - puraDYN® System Start-Up

After (puraDYN® Bypass Oil Filtration System) installation is completed, please perform the following System Start-up to ensure the puraDYN® System is working properly:

1. Fill equipment with oil type and quantity as specified by OEM, and open shut-off valve.
2. Start the engine, check for leaks. If no other issues arise, let engine run for 15 to 30 minutes and check all connections between engine & puraDYN® System again.
3. Shut engine down and let rest for 5 minutes.
4. Open lid and check for oil flow thru filter element. Close lid when done. Alternately, the sample valve may be briefly opened to check for oil flow into the housing unit.
5. Add make-up oil as indicated below (make sure to use same OEM specified oil).

System Model	Make-Up Oil Added
M03	$\frac{3}{4}$ Quarts
M06	1 $\frac{1}{2}$ Quarts
M06W	1 $\frac{1}{2}$ Quarts
M10	2 $\frac{3}{4}$ Quarts

Depending on size and orientation, OEM full flow filters can hold an additional quantity of oil not shown in the oil makeup table above, please add oil as recommended by OEM.

- ✓ Use the engine's oil level dipstick to adjust or determine the proper oil level when installing or replacing oil filters or when performing routine preventive maintenance.
- ✓ Whenever using a bypass filter element for the first time (new install or filter element replacement) remember to allow time for the new bypass element to charge (completely fill with oil), and run for a few minutes after it is charged (filtered oil returning to oil pan) before making final adjustments to the oil level using the OEM oil level dipstick.

6. System Start-Up validated, puraDYN® System is ready to work.

## Sampling Oil Procedures

**Benefit of Oil Sampling Analysis:** As long as the oil sample results returned to you by the independent lab confirm the oil is still good for continued use, there is no need to change your oil.

### Sampling Steps on models with a sampling valve:

- Start the engine and bring oil to operating temperature
- Open oil sample valve
- Draw off 1 cup of oil to purge sediment from oil sample valve
- Open oil sample bottle and draw off oil to fill until 3/4 full
- Close lid on bottle
- Fill out oil sample form completely and mail Oil Analysis kit to lab for analysis.

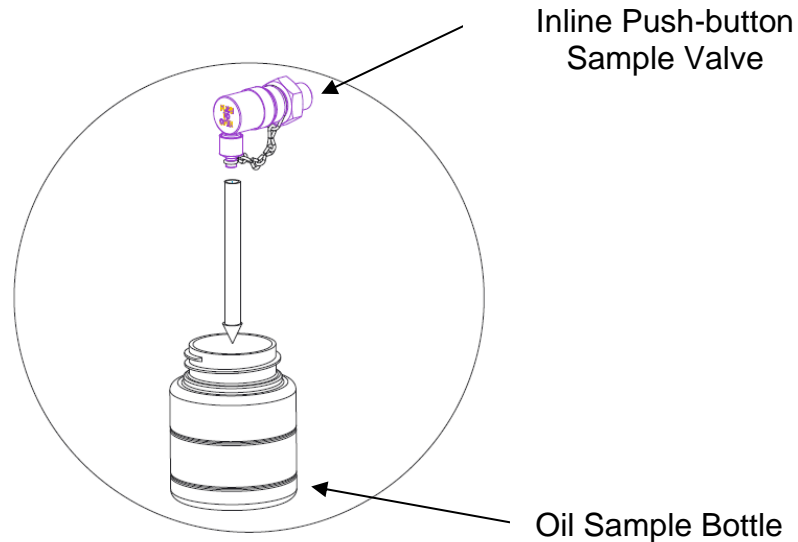

### IMPORTANT:

**Note:** After the puradYN<sup>®</sup> System is installed and start-up validated, please complete Registration Card for warranty coverage and return to Puradyn within 30 days to be in effect. Registration is also available on our website: [www.puradyn.com](http://www.puradyn.com).

## **Oil Analysis Data Interpretation**

The purADYN® Filter Technologies Oil Management Program uses oil analysis results to assist our customers in achieving the benefits of extended oil drain intervals and longer service life for their engines and equipment.

Oil analysis is the key to achieving the benefits of optimizing oil life and extending drain intervals. In addition, oil analysis is the most economical way to measure wear or contamination in the engine or equipment. Of primary importance is the interpretation of the test data. Typical oil analysis reports usually present the data in an easy to understand format and results.

Typical purADYN® oil analysis conducted by an independent laboratory will contain the following parameters and provide a recommendation to continue usage of oil OR change oil:

- **Additive Metals**
- **Total Base Number (TBN) ability to neutralize acid**
- **Wear metals**
- **Liquid Contaminant**
- **Solid Contaminants**

This data must be monitored to fully evaluate the lubrication system. The analysis will provide a “picture” and / or warning, if necessary, of any existing or potential problems.

**Note:** Oil analysis is required in order to maintain Puradyn’s warranty and ensure your purADYN® System filtered oil meets engine manufacturer’s oil specifications.

## Oil Analysis and Service Schedules

Replace the **puraDYN** filter element and perform oil analysis at the oil change intervals recommended by your equipment's Original Engine Manufacturer (OEM). **As long as the oil analysis confirms that the oil is suitable for continued use, the oil does not need to be changed.**

	Before puraDYN Installation	Midpoint of First OEM Interval	Each OEM interval
Take Oil Analysis Sample	✓	✓	✓
Change <b>puraDYN</b> filter and change / clean full flow filter		✓	✓
Change Oil	✓	If analysis requires	If analysis requires

Oil analysis is a fast, non-invasive way to monitor the condition of your engine or hydraulic oil and is key to evaluating the benefits that result from optimized oil life and extended oil drain intervals. In addition, oil analysis is the only economical way to measure wear or contamination in the engine or equipment and often serves as an indicator of potentially costly problems.

Samples are easily taken from the oil sample valve provided with each unit. Sampling the oil before it enters the **puraDYN** system enables an accurate assessment of the condition of the equipment. The oil analysis is conducted by an independent laboratory and is reported in a three-tier test that includes: spectrographic metals, wear metals, and contaminant metals (these metals must be monitored to fully evaluate the lubrication)

For extended oil drain practices relative to over the road trucks, Puradyn follows the Technology & Maintenance Council's (TMC) stringent requirements.

## Troubleshooting

The purADYN® system was designed and engineered to be a powerful oil cleaning device. This purADYN® system is simple to operate and easy to maintain. It is manufactured from the highest quality materials available and with superior workmanship. If, however, your purADYN® system is not functioning properly, check the following conditions, and correct as indicated:

### **1. Restricted oil flow**

### **Remedy**

- |                               |        |                           |
|-------------------------------|--------|---------------------------|
| • Shutoff valve closed        | —————> | Open valve                |
| • Filter dirty and clogged    | —————> | Replace with new filter   |
| • Clogged metering jet screen | —————> | Clean screen thoroughly   |
| • Clogged metering jet        | —————> | Clean assembly thoroughly |

***If you experience any problem with your system not covered in the above trouble shooting guide, please call Puradyn Tech Support at toll-free (in North America) at 1-866-787-2396 or +1 561-547-9499.***

## **Questions & Answers**

### **Q. What type of oil should be used with the puraDYN® System?**

A. Any high quality oil with a high total base number (TBN) or additive package that meets or exceeds the specifications established or recommended by the OEM.

### **Q. Will the puraDYN® System work with the new extended change interval synthetic oils?**

A. Yes. The puraDYN® System is completely compatible with synthetic oils. Although these oils have a superior lubrication value over mineral oils, they are still susceptible to solid contamination buildup and liquid contaminants, such as water and fuel dilution.

### **Q. Can puraDYN® System be used on any engine?**

A. The puraDYN® System can be installed on almost any engine such as automobiles, trucks, buses, boats, generators or any other types of industrial equipment with an engine or pressurized lubricating system.

### **Q. Will the installation of the puraDYN® System on my engine or other type of equipment affects the manufacturer's warranty?**

A. No. The puraDYN® System is a bypass filter cleaning the oil at a rate of 6 gallons (24 liters) per hour and is used in addition to the OEM full flow filter. It enhances the OEM full flow filter's performance, greatly extending its life. We have opinion letters from most major engine manufacturers, such as Detroit Diesel, Caterpillar, Cummins, Ford Motor Co., and many others (copies available upon request), which state that the installation and use of a non-factory accessory, such as the puraDYN® System, does not, in itself, void the manufacturer's warranty.

### **Q. Can puraDYN® System be used on other equipment besides engines?**

A. Yes. The puraDYN® System can be used on many types of hydraulic equipment, compressors as well as most engines that do not use a pressurized sump.



**Q. How difficult is it to install the puraDYN® System?**

A. The puraDYN® System can be easily installed on almost any engine (this includes engines with metric fittings) in usually 2 hours or less. Detailed instructions for do-it-yourself installations are provided or any qualified mechanic can easily perform the installation.

**Q. Will the puraDYN® System cause a drop in oil pressure?**

A. No. The oil will build up a head of pressure against the metering jet at the bottom of the puraDYN® System and will not change the oil pressure of the engine or affect the normal operation of the engine or the OEM full-flow filter.

**Q. At what rate does the puraDYN® System clean the oil?**

A. The puraDYN® System cleans the oil at approximately 6 gallons per hour at 65 psi.

**Q. What is the puraDYN® System warranty?**

A. The puraDYN® System carries a 5-year unlimited miles or hours warranty against defects in materials and workmanship, with a six-month money-back performance guarantee. Consumables not covered include O-rings, gaskets and filter elements from normal wear". Please call Puradyn for more details.

**Q. Should I change my existing oil when fitting a puraDYN® System to my truck, car, or other equipment?**

A. Yes. It is best to start out with new oil where the viscosity and additive levels are a known factor. In addition, we recommend taking a sample of the new oil and a sample of the drained oil to establish a base line for later comparisons.

## ***Maintenance:***

### **Cleaning the Metering Jet and Screen**

Rarely does the metering jet itself get plugged. However, the protective mesh screen may build up debris or large particles that could impede oil flow over time.

***IMPORTANT:*** *When the engine or equipment is turned off. Carefully remove the supply hose from each supply fitting (residual oil may still be present in fittings, bypass system or hose). Blow out the oil supply hose with high air pressure before proceeding to refastening supply hose. Failure to do so will result in hose, screen or metering jet becoming clogged again.*

### **Canister and Metering Jet Dis-Assembly**

1. Loosen and remove supply fitting on the bottom of the housing unit.
2. Carefully remove metering jet screen from the supply port (use caution to avoid damaging port threads).
3. Using a Hex Drive remove the metering jet.
4. Reinstall in reverse order from Step 3.

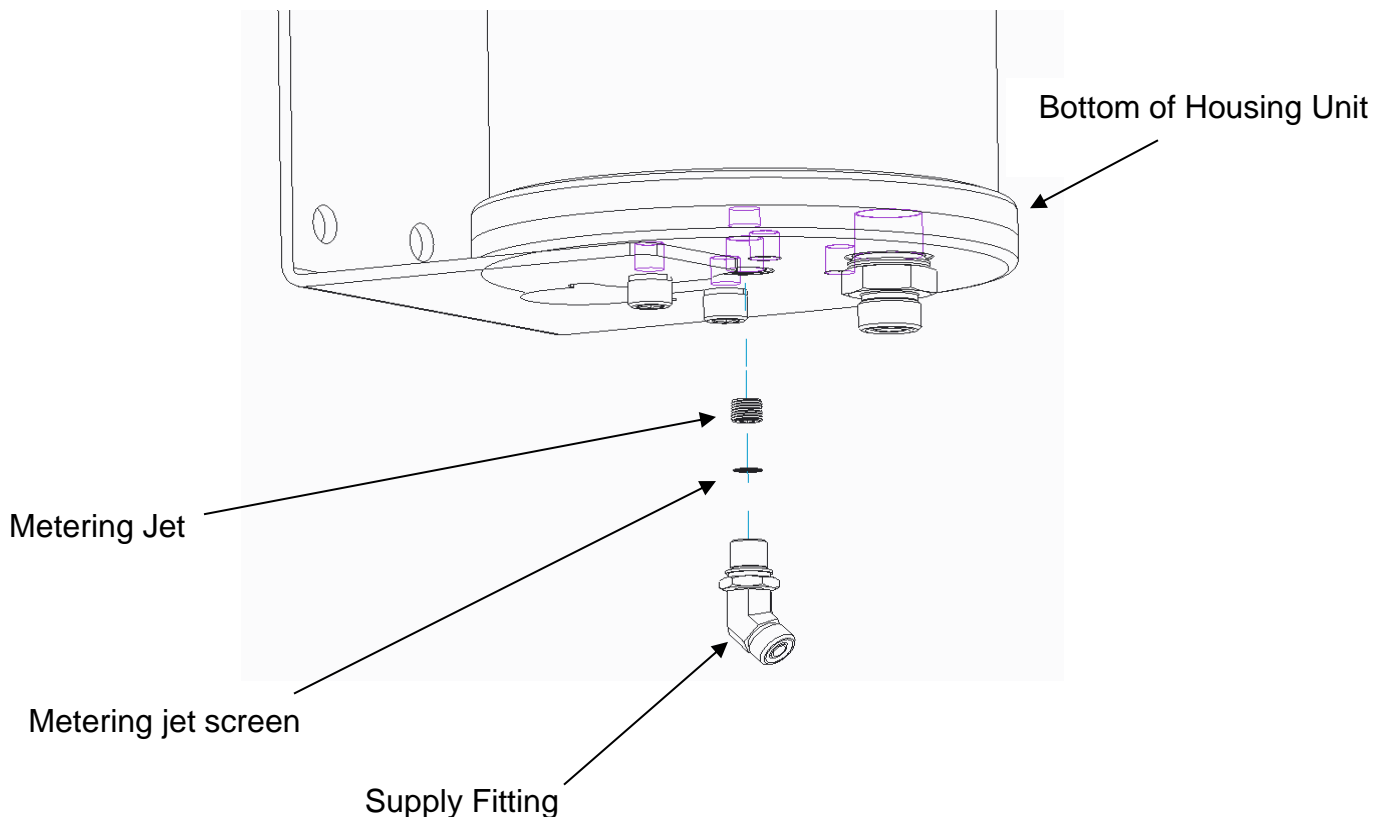

## Filter Element Service Requirements

**WARNING:  
HOUSING UNIT IS HOT  
USE CAUTION**

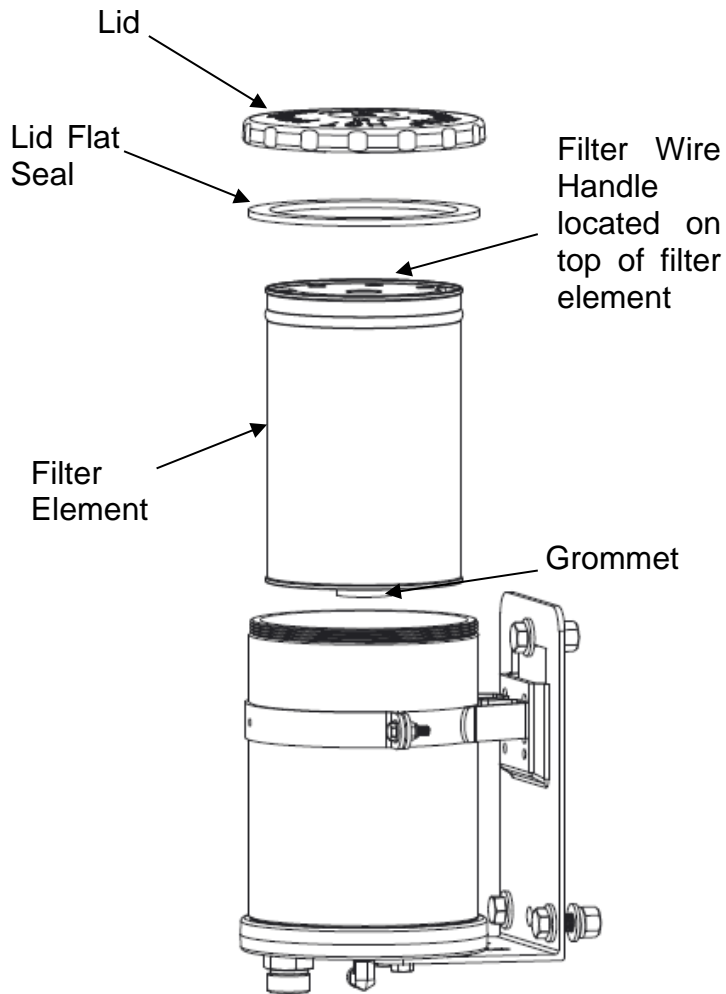

### **Lid Removal, Filter Element Replacement and Lid Reinstall**

1. Using 24" –long flex handle with ½" drive, turn lid counterclockwise and remove.
2. Reuse (new filter packing plastic bag) disposable bag, remove spent filter gently by pulling up on wire handle/s and drop into the plastic bag for disposal.
3. Install new filter by pushing it gently down into the filter housing; make sure the rubber grommet fits securely over the nipple.
4. Thoroughly clean lid and gasket surface.
5. Lightly lubricate gasket with clean oil.
6. Hand-install and spin lid on clockwise until contact with gasket (hand tight).
7. Tighten Model M06W / M10 (prev. MTS-12 / MTS-24) lid to 55 to 65 ft-lb) torque or approximately additional half turn (after hand-tight) using the 24"-long flex handle.
8. Tighten Model M03 / M06 (prev. MTS-8 / MTS-8x12) lid to (30 - 40 ft-lb) torques or approximately additional quarter turn (after hand-tight) using the 24"-long flex handle.

## **Required Tools and Items for puraDYN® System Installation**

1. Drill and assorted drill bits
2. Teflon paste or equivalent thread sealant
3. Open-end wrench assortment
4. 3/8" or 1/2" drive ratchet with socket assortment
5. Large, adjustable crescent wrench
6. Hacksaw
7. Utility knife
8. Center punch
9. Optional banjo fitting to make return hose connection to engine
10. 3/16" I.D. high-pressure hose
11. 13/32" I.D. return hose
12. Oil analysis kit(s)
13. New OEM full-flow oil filter(s)
14. New oil, as recommended by engine manufacturer
15. Oil pressure gauge (to verify oil pressure is below 110 psi)
16. Compressed air to blow out pressure hose upon assembling fittings
17. Safety eye protectors (shop type)
18. Protective gloves to handle hot oil
19. Allen wrenches (U.S. standard sizes)



**Puradyn Filter Technologies Incorporated**  
**PRODUCT LIMITED WARRANTY**  
**puradYN® Bypass Oil Filtration System**

**Limited Warranty**

The **puradYN** bypass oil filtration system is warranted to be free from defects in material and workmanship for a period of five (5) years from the date of purchase, with the exception of the heating element which is warranted for one (1) year from the date of purchase. All optional, off-the-shelf, third party parts are not warranted. This warranty is only available to the original end-user purchaser and is not assignable or transferable. You **MUST** return the registration card completely filled out (or register and submit the online registration form at [www.puradyn.com](http://www.puradyn.com)) within 30 days of your purchase as a condition precedent to receive coverage and performance under our warranty. Further, your failure to provide proof of purchase, which clearly states the date of purchase, shall void this warranty and the obligations and rights hereunder.

The **puradYN**, including any defective part therein, must be returned to an authorized sales representative, dealer, distributor, or to Puradyn within the material and workmanship warranty period. The sales representative, dealer, distributor, or Puradyn will then execute the warranty procedures on the owner's behalf. Puradyn's responsibility in respect to warranty claims is limited to providing the required repairs or replacements to the product itself, and no claim of breach of warranty shall be cause for cancellation or rescission of the contract of sale of any Puradyn products.

For warranty questions or issues, please contact: Puradyn Filter Technologies Incorporated, Attention: Warranty Department, 2017 High Ridge Road, Boynton Beach, FL 33426 USA (T) +1 561 547 9499. If the product is not free from defects in materials and workmanship during the warranty period, Puradyn, at its option and expense will (i) repair the subject product by your return of the product to Puradyn, (ii) replace the subject product by having the replacement sent to your location, or (iii) refund the purchase price for the product as identified in your proof of purchase. In the event that without prior consultation with Puradyn, repair work or any other change to the damage is executed, the right to warranty is invalidated and Puradyn is not bound to pay any compensation for damage. For other claims, including bodily injury based on the deficiency of the **puradYN** system, the legal stipulations apply (see below).

This warranty does not cover any economic loss, including without limitation, communication expenses, towing mechanic's travel time and/or mileage, meals, lodging, loss of use of the engine or equipment, loss of time, revenue, inconvenience, cargo damage, premium charged for overtime labor requested by the purchaser, and for any service and/or maintenance, or any other cost or expense resulting from a defect covered by this warranty. Repairs or replacements due to an accident, failure to follow operating instructions, misuse, alteration, misapplication, storage damage, negligence, modification exceeding **puradYN** system specifications, or improper installation are not covered by this warranty. The above-mentioned warranty and Puradyn's liability will never extend beyond (the consequence of) defects in the **puradYN** systems themselves. Damage caused by other means or by third parties, such as errors during installation or by incorrect mounting of pieces of hoses, is not covered either by this warranty or by product liability.

This Warranty expires if and when:

- a. The **puradYN** systems are handled without due care or in contradiction with the instructions for use, or if used for purposes other than its appropriate purpose.
- b. Cartridges other than the original **puradYN** filter elements have been applied.
- c. The defect and/or damage is a result of a natural disaster, act of God, act of terrorism or military action, improper storage, embargoes, accident, misuse, incorrect use or any other outside cause or condition beyond Puradyn's control.

Puradyn reserves the right to change or improve the design of any Puradyn product without assuming any obligation to modify any Puradyn product previously manufactured. The product may contain certain components that have been remanufactured or refurbished following limited prior use.

*EXCEPT AS STATED ABOVE, PURADYN SHALL NOT BE LIABLE IN CONTRACT, TORT, STRICT LIABILITY OR NEGLIGENCE FOR ANY DIRECT, INCIDENTAL OR CONSEQUENTIAL DAMAGES OR FOR BREACH OF ANY WRITTEN OR IMPLIED WARRANTY. PURADYN NEITHER ASSUMES NOR AUTHORIZES ANY OTHER PERSON TO ASSUME FOR PURADYN ANY OTHER LIABILITY IN CONNECTION WITH THE SALE OF THE PRODUCT. EXCEPT FOR THE EXPRESS WARRANTY STATED ABOVE, THERE ARE NO WARRANTIES EXPRESSED OR IMPLIED. THIS WARRANTY SHALL BE GOVERNED BY AND CONSTRUED, INTERPRETED, AND ENFORCED IN ACCORDANCE WITH THE LAWS OF THE STATE OF FLORIDA, USA. EXCLUSIVE VENUE AND JURISDICTION SHALL BE IN PALM BEACH COUNTY, FLORIDA, USA.*

19-00014\_Product\_Warranty\_101907\_Rev5



**Puradyn Filter Technologies Incorporated**  
**PRODUCT LIMITED LIABILITY GUARANTEE**  
**puradYN® Bypass Oil Filtration System**

**Our Guarantee**

Puradyn carries a \$1,000,000 (per occurrence) domestic and international Commercial Liability Policy to protect your investment while saving you money. All optional, off-the-shelf, third-party parts are not covered under our product limited liability guarantee.

PFTI shall repair the damage to any engine caused directly and solely by the **puradYN** provided that **1)** the **puradYN** is properly installed and maintained in accordance with the prescribed installation guidelines and service intervals contained in the PFTI installation manual; **2)** the **puradYN** is installed and maintained on an engine which is in normal running and mechanical condition at the time of installation and which continues to be properly maintained in accordance with the engine manufacturer's recommended service intervals (other than recommended oil changes); **3)** the **puradYN** is installed on an engine in which the replacement engine oil meets or exceeds the engine manufacturer's recommended grade of engine oil; **4)** the proper **puradYN** filter elements and the engine's standard full-flow filter elements are installed, used and replaced in accordance with the PFTI installation manual; and **5)** the oil analyses are performed by a qualified laboratory at the same intervals you change the **puradYN** filter element, but at least once a year.

Additionally, within five calendar days following the discovery of such damage, the customer must give written notice to Puradyn Filter Technologies Incorporated, 2017 High Ridge Road, Boynton Beach, Florida 33426, and allow a service representative of PFTI to **(a)** examine the damaged engine on which the **puradYN** is installed; **(b)** examine the oil inside said damaged engine at the time such damage is discovered; **(c)** examine the required periodic oil analysis reports; and **(d)** examine the installation of the **puradYN** at the time damage is discovered in order to permit PFTI to determine the extent of damage and whether it was caused solely and directly by the **puradYN**.

PFTI\_Product\_Liability\_012011\_Rev1

## OIL ANALYSIS AND SERVICE SCHEDULE RECORDING TEMPLATE

Interval	Old Oil Baseline	New <b>paraDYN®</b>	One Half Interval	OEM Interval	OEM Interval	OEM Interval
Engine Hours Hrs or Miles	Log	<b>0 hrs</b>	Log	Log	Log	Log
Oil Analysis Sample	Sample Date	Sample Date		Sample Date	Sample Date	Sample Date
<b>paraDYN® Filter</b>	Change Date		<u>Change Date</u>	<u>Change Date</u>	<u>Change Date</u>	<u>Change Date</u>
Full Flow Filter	Change Date			<u>Change Date</u>	<u>Change Date</u>	<u>Change Date</u>
Lab Results will indicate recommendation	Oil Change No Change	<u>New Oil</u>		Oil Change No Change	Oil Change No Change	Oil Change No Change

### NOTES



**Puradyn Filter Technologies Incorporated**  
**2017 High Ridge Road**  
**Boynton Beach, Florida 33426**  
**(T) +1 561 547 9499**  
**Toll Free (in N. A.): 866-PURADYN (787 2396)**  
**(F) +1 561 547 8629**  
<https://www.puradyn.com>

**Protect Your Investment!**  
REGISTER YOUR PRODUCT FOR WARRANTY COVERAGE  
**Online at [www.puradyn.com](http://www.puradyn.com)**

Purchased by: \_\_\_\_\_ Date: \_\_\_\_\_

Installed by: \_\_\_\_\_ Date: \_\_\_\_\_

Record filtration system serial # (found on housing unit) for future reference:

\_\_\_\_\_

\_\_\_\_\_